

HANGCHA GROUP CO., LTD.

Factory site: 666 Xiangfu Road,
Hangzhou, Zhejiang, China (311305)

Tel: +86-571-88926735 88926755
Fax: +86-571-88926789 88132890

sales@hcforklift.com www.hcforklift.com

HANGCHA GROUP CO., LTD. reserves the right to make any changes without notice concerning colors, equipment, or specifications detailed in this brochure, or to discontinue individual models. The colors of trucks, delivered may differ slightly from those in brochures.



Follow us on
Facebook



Follow us on
YouTube



Follow us on
WeChat



Download "Hangcha
Forklift" App



ISO45001:2018



ISO14001:2015



ISO9001:2015



HANGCHA trucks conform to the European Safety Requirements.

AUTHORIZED DEALER



Pro



XC SERIES

4-W ELECTRIC FORKLIFT TRUCK
WITH LITHIUM POWER

With capacity of 1,500 to 3,800kg



TOTAL COMFORT

The dashboard in the driver's cab is placed on the right side of the instrument rack, accessible and easy to operate. Comfortable acceleration control and regenerative braking function can effectively reduce the driver's fatigue.

With the standard multi-way valve manipulator handle, the manipulation force is **reduced by 20%**, and the standard lifting sensor and the new type of load-sensing multi-way valve allow comfortable operation and better inching performance.



Optional fingertip integrated operating system and rocker handle operating system, the combined operating armrest integrates the emergency cut-off, horn and switches, etc., is electrically controlled through the CAN bus and is highly reliable.



The whole truck, continuing the advantages of XC series specialized platform, has a large operating space more than **50% larger** than that of the traditional electric truck.

The wide-view mast with optimized design is unlikely to obstruct the operator's line of sight. The enlarged opening size of the fork carriage enables a wider view.

SOFT LANDING

The intelligent sensing enables soft landing. When the fork is 100 - 60mm away from the ground, the descending will automatically slow down, so that the goods and pallet will not hit the ground and the goods and ground can be protected effectively.

100-60mm



The color-screen instruments are designed to have graphic interfaces featuring intuitive reading and friendly human-computer interfaces.



Owing to the low center of gravity and good stability, the driver feels comfortable during turning.



The whole truck boasts silence, no pollution, energy saving and other advantages, and meets the environmental protection requirements.



The ergonomically designed tilt-adjustable small-diameter steering wheel makes the driver feel good. The seat can be adjusted back and forth by 210mm. The operator can choose the best driving position.

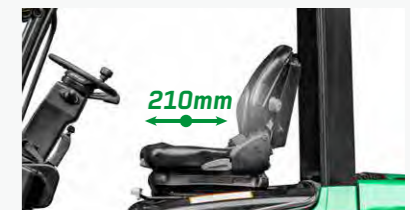

MAIN ACCESSORIES

- The main electrical components such as the motor controller, contactor, power plug, emergency cut-off switch, dashboard, accelerator, are all products of well-known foreign brands.
- The emergency cut-off switch equipped for the standard configuration complies with European safety regulations.
- Electronic and hydraulic overload protection devices.



The truck has passed CE certification.



ADVANCEMENT

The high-frequency MOSFET integrated controller ensures smooth and accurate driving and lifting control, and has excellent speed regulation performance, good performance of electronic control matching the motor, functions of regenerative braking, reverse braking and anti-sliding on ramps, etc. and high safety and reliability.



The noise can be as low as 70dBA.



Energy consumption comparison

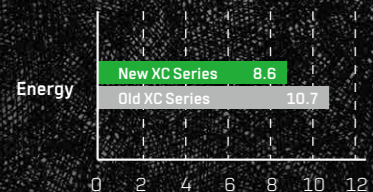

Battery life comparison

*Under the same working environment

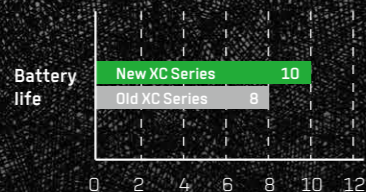

Travel speed (km/h)

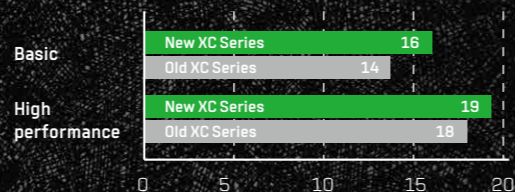

With the high-power oil pump motor and the matching handle operation, the system has high efficiency, complete protection functions, built-in speed and temperature sensors, and greatly improved reliability and life.

The high-power traveling motor is adopted to realize strong climbing ability, fast response speed and smooth start.

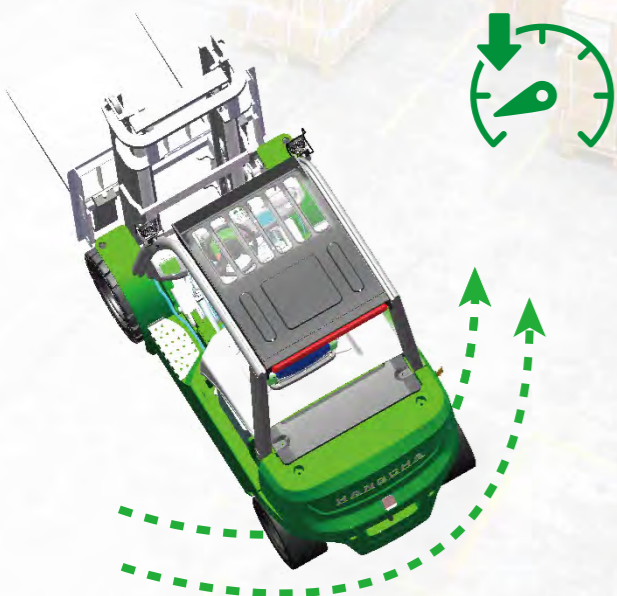

The rear axle is provided with a flexible suspension system (with turning and deceleration functions for standard configuration) to effectively filter the road clutter, and with the high-level connection to greatly improve the driver's comfort.

The EPB (Electric Parking Brake) (optional) and steering wheel adaptive steer control (optional) greatly improve the comfort.



SAFE AND RELIABLE.

- The standard configuration provides a fork descending buffering function. In addition, an optional electronic control function for buffering the fork's ascending is provided to protect the goods from falling and damaging the ground.
- The handbrake can be optionally equipped with an alarm buzzer to prompt the driver to pull up the handbrake before leaving the truck.
- Optional electric handbrake configured is provided with automatic parking and ramp holding function.



The optional descending lock function can disable the descending function when the driver leaves the seat and enable high safety.



Three horn buttons are provided, which are respectively on the driver's steering wheel, thumb switch equipped armrest (optional) and reverse armrest (optional), for alerting and protecting the surrounding people.

EASY OPERATIONS AND REPAIR

- With the fully sealed hood and side plates, all major components including the electrically controlled components, motor, electrical components, etc. are sealed from dust and water.
- The drive motor of a high protection level is dustproof and waterproof and highly reliable.
- The water resistance level of the truck is IPX4.

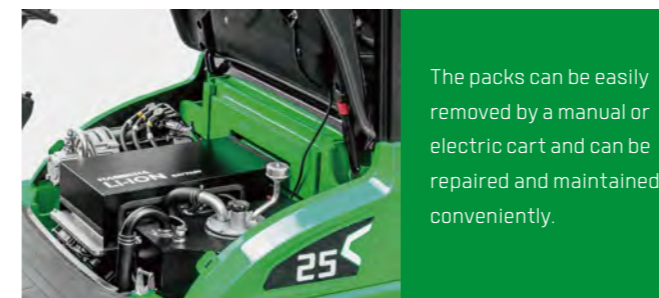

The packs can be easily removed by a manual or electric cart and can be repaired and maintained conveniently.

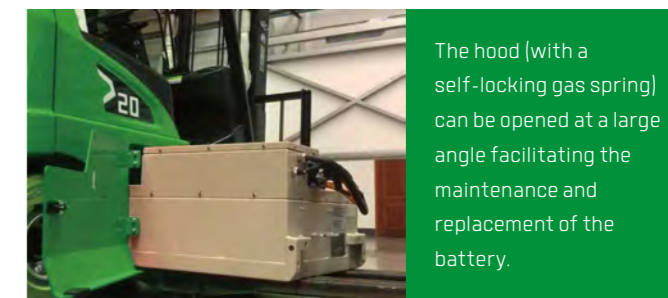

The hood (with a self-locking gas spring) can be opened at a large angle facilitating the maintenance and replacement of the battery.



KEEP AN EYE ON EVERYTHING

Hangcha FIMS is a system that provides you with real-time information about forklift truck and driver. Whether you have dozens or hundreds of forklift trucks across multiple sites, you can get access to collecting, monitoring and evaluating all the fleet data at anytime and anywhere.

»» Features

- ▶ Access Control
- ▶ GPS Tracking
- ▶ Remote Monitoring
- ▶ Maintenance Reminder
- ▶ Vehicle Management
- ▶ Vibration Monitoring
- ▶ Pre-shift Check (Optional)
- ▶ Shift Management (Optional)
- ▶ OpenAPI (Optional)

LITHIUM POWERED

EMPOWER YOURSELF
WITH THE BEST



Li
Lithium

POWER THE POSSIBILITIES
RELIABLE LITHIUM-ION TECHNOLOGY



LITHIUM BATTERY ADVANTAGES



Long service life

4000 full charging cycles with at least 75% residual capacity.



Return on investment

Add flexibility to your operation, cost-saving in the long term, increased efficiencies.



Maintenance free

No topping up of water or checking acid levels.



High energy density

The high energy density of the Li-Ion battery ensures long working times and increases the high availability.



Cold area application

Li-Ion batteries maintain high performance at temperatures below freezing.



High safety and reliability

Intelligent battery management monitoring every important function, no emission of battery gasses.



Opportunity charging

Full performance during several shifts thanks to effective interim charging.

FEATURES & BENEFITS THE HANGCHA DIFFERENCE

Efficiency

By quick opportunity charging any downtime, such as a lunch break, can be efficiently used and the battery is recharged in a very short period of time. Interim charging does not affect the battery service life.

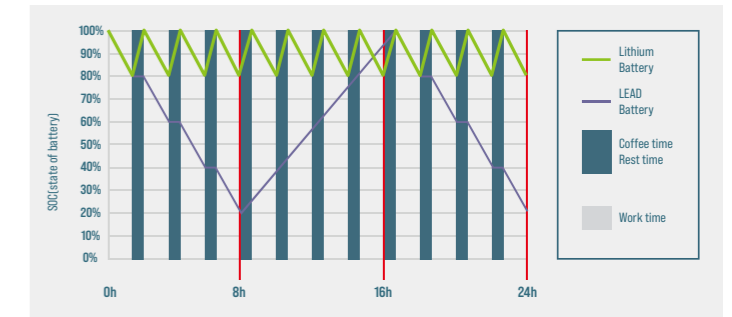

Safety

- / Intelligent battery management monitoring every important function.
- / Higher user safety, thanks to acid-free use.
- / User friendly due to avoided battery change.
- / No emission of battery gasses.

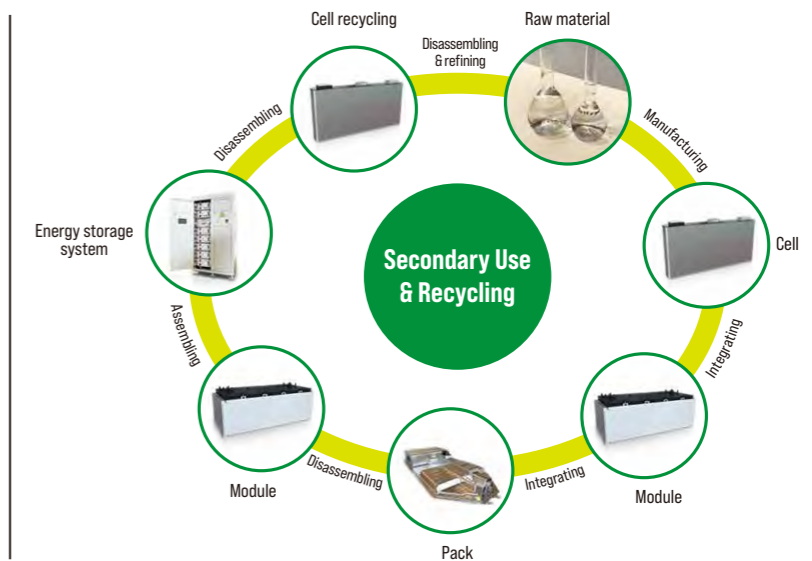

QUESTION 1

Q: What are the characteristics of lithium batteries, especially when used in high and low temperature environments?

Charging temperature: -30 C - 65 C
 Discharge temperature: -30 C - 65 C
 Storage environment temperature: -30 C - 65 C

After the truck key switch is closed, the instrument battery condition needs to be checked:

1. Confirm that there is no battery system alarm message on the instrument panel.
2. Please check the remaining power before use. It is recommended to use the SOC between 50% and 100%.
3. If the SOC is lower than 20%, it is not recommended to continue using it. Please charge it as soon as possible.

QUESTION 2

Q: What is the charging time and usage time calculation of forklift lithium battery?

1. Available power of lithium battery (kWh) = rated voltage * rated power * 90% (To avoid over-discharge damaging the battery, the forklift is equipped with low power protection [less than 10%]).
 2. Charging time (h) = rated capacity of lithium battery (Ah) * 90% * charger output current (A).
 3. The power consumed for charging (kWh) = the available power of the lithium battery * 93% (the charging efficiency of the charger is calculated as 93%).
 4. Usage time (h) = available power of lithium battery * energy consumption data.
- For specific energy consumption values, please refer to the technical table on the sharing platform.**

QUESTION 3

Q: How does Hangcha BMS work to ensure the safety of the lithium battery?

HANGCHA BMS (battery management system) can monitors the cells at all time. As a result, hangcha lithium power is the reliable solution.



Battery Safety Management:

- Overcharge/over discharge protection
- Overcurrent/over-temperature/low-temperature protection
- Multi-level fault diagnosis protection
- Double fault monitoring



Battery Parameter Detection:

- Battery voltage detection and analysis
- Battery current detection and analysis
- Battery temperature detection and analysis



Equilibrium Management:

- Equalization based on voltage mode
- Equalization based on time mode
- Equalization based on battery cell SOC
- Active/passive equalization optional



Other Features:

- Low cost, low power consumption
- Historical data record
- Flexible cascade expansion
- CRC data validation

LI-ION BATTERIES AND CHARGERS

IT'S FASTER AND EASIER WITH HANGCHA

Innovative, reliable lithium-ion technology (Lithium Iron-Phosphate), which are developed jointly by HANGCHA and CATL. Battery cells and modules are from CATL, with reliable quality, exclusively for HANGCHA.



Integrated Battery Management System (BMS) continually monitors energy management and ensures reliable operation. HANGCHA provides Li-Ion battery (LiFePO4) with **6 years** or **12000 hours** warranty.

HANGCHA WARRANTY SERVICE

6 YEARS WARRANTY

Charger model:

SLC-80100
SLC-80200

Output voltage range (V):

80V charger: 40Vdc - 100Vdc

Output current range (A):

100A charger: 5A - 100A(SLC-80100)

200A charger: 5A - 200A(SLC-80200)

Battery Parameters

	Nominal Voltage[V]	Nominal Capacity[Ah]	Battery Weight[kg]	Operating Temperature-Discharge(°C)	Operating Temperature-Charge(°C)	Protection Class
XIPD151-730000-800	80V	304Ah	210kg	-30 C -65 C	0 C -60 C	IP67
XIPD151-730000-810	80V	230Ah	230kg	-30 C -65 C	0 C -60 C	IP67
XIPD253-730000-800	80V	304Ah	225kg	-30 C -65 C	0 C -60 C	IP67
XIPD253-730000-810	80V	304Ah	300kg	-30 C -65 C	0 C -60 C	IP67
XIPD252-730000-510	80V	410Ah	300kg	-30 C -65 C	0 C -60 C	IP67
XIPD253-730000-830	80V	280Ah	225kg	-30 C -65 C	0 C -60 C	IP67
XIPD352-730000-800	80V	460Ah	300kg	-30 C -65 C	0 C -60 C	IP67
XIPD352-730000-810	80V	560Ah	385kg	-30 C -65 C	0 C -60 C	IP67
XIPD352-730000-830	80V	410Ah	300kg	-30 C -65 C	0 C -60 C	IP67

EVE Battery Capacity (Std.)

Capacity[Ah]	XC-pro Standard				XC-pro High performance	
	1.5-mini2.0t	2-2.5t	3-3.5t	3.8t	2-2.5t	3-3.5t
173	●	/	/	/	/	/
230	○	●	/	/	/	/
280	○	○	/	/	/	/
304	○	○	●	/	●	/
346	/	○	○	/	○	/
460	/	○	○	●	○	●
560	/	/	○	○	/	○
608	/	/	○	○	/	○

Note: ● Standard ; ○ Optional

CATL Battery Capacity (Opt.)

Capacity[Ah]	XC-pro Standard				XC-pro High performance	
	1.5-mini2.0t	2-2.5t	3-3.5t	3.8t	2-2.5t	3-3.5t
173	○	/	/	/	/	/
228	○	○	/	/	/	/
302	○	○	○	/	○	/
456	/	○	○	○	○	○
604	/	/	○	○	/	○

Note: ● Standard ; ○ Optional

FAST STRONG SMART

Pro



1.5t Mast Specification

Type	Model	Max. fork height	Overall height			Free lift height		Tilt range FWD/RWD [°]	Capacity		
			Lowered	Extended		Without backrest	With backrest		Load Capacity at 500mm		
				Without backrest	With backrest				Single Tire	Double tire	
									1.5t	1.5t	
mm	mm	mm	mm	mm	mm	kg	kg				
Wide view Duplex mast	XCP15M270	2700	1845	3243	3655	135	135	6/12	1500	1500	
	XCP15M300	3000	1995	3543	3955	135	135	6/12	1500	1500	
	XCP15M330	3300	2145	3843	4255	135	135	6/12	1500	1500	
	XCP15M350	3500	2245	4043	4455	135	135	6/12	1500	1500	
	XCP15M370	3700	2395	4243	4655	135	135	6/12	1500	1500	
	XCP15M400	4000	2595	4550	4955	135	135	6/12	1500	1500	
	XCP15M450	4500	2845	5050	5455	135	135	6/6	1500	1500	
	XCP15M500	5000	3095	5550	5955	135	135	6/6	1350	1400	
Free duplex wide-view mast	XCP15U270	2700	1845	3274	3645	1271	900	6/12	1500	1500	
	XCP15U300	3000	1995	3574	3945	1421	1050	6/12	1500	1500	
	XCP15U330	3300	2145	3874	4245	1571	1200	6/12	1500	1500	
	XCP15U350	3500	2245	4074	4445	1671	1300	6/12	1500	1500	
	XCP15U370	3700	2345	4274	4645	1771	1400	6/12	1500	1500	
	XCP15U400	4000	2545	4574	4945	1971	1600	6/12	1500	1500	
	Free triplex wide-view mast	XCP15N400	4000	1945	4584	4955	1371	1000	6/6	1500	1500
		XCP15N430	4300	2045	4884	5255	1471	1100	6/6	1500	1500
XCP15N450		4500	2095	5084	5455	1521	1150	6/6	1500	1500	
XCP15N470		4700	2195	5284	5655	1621	1250	6/6	1400	1500	
XCP15N480		4800	2195	5384	5755	1621	1250	6/6	1400	1500	
XCP15N500		5000	2295	5584	5955	1721	1350	6/6	1400	1450	
XCP15N550		5500	2445	6084	6455	1871	1500	3/6	1250	1350	
XCP15N600		6000	2645	6584	6955	2071	1700	3/6	1100	1150	
XCP15N650	6500	2845	7084	7455	2271	1900	3/6	/	900		

With sidershifter minus 150kg, with integrated sidershifter minus 100kg.

1.8t Mast Specification

Type	Model	Max. fork height	Overall height			Free lift height		Tilt range FWD/RWD [°]	Capacity		
			Lowered	Extended		Without backrest	With backrest		Load Capacity at 500mm		
				Without backrest	With backrest				Single Tire	Double tire	
									1.8t	1.8t	
mm	mm	mm	mm	mm	mm	kg	kg				
Wide view Duplex mast	XCP18M270	2700	1845	3348	3655	135	135	6/12	1800	1800	
	XCP18M300	3000	1995	3648	3955	135	135	6/12	1800	1800	
	XCP18M330	3300	2145	3948	4255	135	135	6/12	1800	1800	
	XCP18M350	3500	2245	4148	4455	135	135	6/12	1800	1800	
	XCP18M370	3700	2395	4348	4655	135	135	6/12	1800	1800	
	XCP18M400	4000	2595	4648	4955	135	135	6/12	1800	1800	
	XCP18M450	4500	2845	5148	5455	135	135	6/6	1650	1700	
	XCP18M500	5000	3095	5648	5955	135	135	6/6	1550	1600	
Free duplex wide-view mast	XCP18U270	2700	1845	3384	3645	1161	900	6/12	1800	1800	
	XCP18U300	3000	1995	3684	3945	1311	1050	6/12	1800	1800	
	XCP18U330	3300	2145	3984	4245	1461	1200	6/12	1800	1800	
	XCP18U350	3500	2245	4184	4445	1561	1300	6/12	1800	1800	
	XCP18U370	3700	2345	4384	4645	1661	1400	6/12	1800	1800	
	XCP18U400	4000	2545	4684	4945	1861	1600	6/12	1800	1800	
	Free triplex wide-view mast	XCP18N400	4000	1945	4694	4955	1261	1000	6/6	1800	1800
		XCP18N430	4300	2045	4994	5255	1361	1100	6/6	1650	1800
XCP18N450		4500	2095	5194	5455	1411	1150	6/6	1650	1750	
XCP18N470		4700	2195	5394	5655	1511	1250	6/6	1600	1650	
XCP18N480		4800	2195	5494	5755	1511	1250	6/6	1600	1650	
XCP18N500		5000	2295	5694	5955	1611	1350	6/6	1550	1600	
XCP18N550		5500	2445	6194	6455	1761	1500	3/6	1500	1550	
XCP18N600		6000	2645	6694	6955	1961	1700	3/6	1300	1400	
XCP18N650	6500	2845	7194	7455	2161	1900	3/6	/	1150		

With sidershifter minus 150kg, with integrated sidershifter minus 100kg.

Mini2.0t Mast Specification

Type	Model	Max. fork height	Overall height			Free lift height		Tilt range	Capacity			
			Lowered	Extended		Without backrest	With backrest		Load Capacity at 500mm			
				Without backrest	With backrest				Single Tire		Double tire	
									2.0t	2.0t		kg
Wide view Duplex mast	XCPX20M270	2700	1845	3263	3655	140	140	6/12	2000	2000		
	XCPX20M300	3000	1995	3563	3955	140	140	6/12	2000	2000		
	XCPX20M330	3300	2145	3863	4255	140	140	6/12	2000	2000		
	XCPX20M350	3500	2245	4063	4455	140	140	6/12	2000	2000		
	XCPX20M370	3700	2395	4263	4655	140	140	6/12	2000	2000		
	XCPX20M400	4000	2595	4563	4955	140	140	6/12	2000	2000		
	XCPX20M450	4500	2845	5063	5455	140	140	6/6	1850	1900		
	XCPX20M500	5000	3095	5563	5955	140	140	6/6	1650	1750		
Free duplex wide-view mast	XCPX20U270	2700	1845	3253	3645	1292	900	6/12	2000	2000		
	XCPX20U300	3000	1995	3553	3945	1442	1050	6/12	2000	2000		
	XCPX20U330	3300	2145	3853	4245	1592	1200	6/12	2000	2000		
	XCPX20U350	3500	2245	4053	4445	1692	1300	6/12	2000	2000		
	XCPX20U370	3700	2345	4253	4645	1792	1400	6/12	2000	2000		
	XCPX20U400	4000	2545	4553	4945	1992	1600	6/12	2000	2000		
Free triplex wide-view mast	XCPX20N400	4000	1945	4563	4955	1392	1000	6/6	1950	2000		
	XCPX20N430	4300	2045	4863	5255	1492	1100	6/6	1850	1950		
	XCPX20N450	4500	2095	5063	5455	1542	1150	6/6	1800	1900		
	XCPX20N470	4700	2195	5263	5655	1642	1250	6/6	1750	1850		
	XCPX20N480	4800	2195	5363	5755	1642	1250	6/6	1750	1850		
	XCPX20N500	5000	2295	5563	5955	1742	1350	6/6	1700	1800		
	XCPX20N550	5500	2445	6063	6455	1892	1500	3/6	1650	1750		
	XCPX20N600	6000	2645	6563	6955	2092	1700	3/6	1450	1500		
	XCPX20N650	6500	2845	7063	7455	2292	1900	3/6	/	1350		

With sideshifter minus 150kg, with integrated sideshifter minus 100kg.

2.0-2.5t Mast Specification

Type	Model	Max. fork height	Overall height			Free lift height		Tilt range	Capacity			
			Lowered	Extended		Without backrest	With backrest		Load Capacity at 500mm			
				Without backrest	With backrest				Single Tire		Double tire	
									2.0t	2.5t	2.0t	2.5t
Wide view Duplex mast	XCP25M270	2700	1850	3337	3746	140	140	6/12	2000	2500	2000	2500
	XCP25M300	3000	2000	3637	4046	140	140	6/12	2000	2500	2000	2500
	XCP25M330	3300	2150	3937	4346	140	140	6/12	2000	2500	2000	2500
	XCP25M350	3500	2250	4137	4546	140	140	6/12	2000	2500	2000	2500
	XCP25M370	3700	2400	4337	4746	140	140	6/12	2000	2500	2000	2500
	XCP25M400	4000	2600	4637	5046	140	140	6/12	2000	2500	2000	2500
	XCP25M430	4300	2750	4937	5346	140	140	6/6	2000	2500	2000	2500
	XCP25M450	4500	2850	5137	5546	140	140	6/6	2000	2450	2000	2500
	XCP25M500	5000	3100	5637	6046	140	140	6/6	1850	2300	1950	2350
Free duplex wide-view mast	XCP25U270	2700	1850	3361	3746	1189	804	6/12	2000	2500	2000	2500
	XCP25U300	3000	2000	3661	4046	1339	954	6/12	2000	2500	2000	2500
	XCP25U330	3300	2150	3961	4346	1489	1104	6/12	2000	2500	2000	2500
	XCP25U350	3500	2250	4161	4546	1589	1204	6/12	2000	2500	2000	2500
	XCP25U370	3700	2350	4361	4746	1689	1304	6/12	2000	2500	2000	2500
	XCP25U400	4000	2550	4661	5046	1889	1504	6/12	2000	2500	2000	2500
Free triplex wide-view mast	XCP25N400	4000	1950	4661	5046	1289	904	6/6	2000	2500	2000	2500
	XCP25N430	4300	2050	4961	5346	1389	1004	6/6	2000	2450	2000	2500
	XCP25N450	4500	2100	5161	5546	1439	1054	6/6	2000	2350	2000	2450
	XCP25N470	4700	2200	5361	5746	1539	1154	6/6	1950	2250	2000	2350
	XCP25N480	4800	2200	5461	5846	1539	1154	6/6	1950	2250	2000	2350
	XCP25N500	5000	2300	5661	6046	1639	1254	6/6	1850	2150	1950	2250
	XCP25N550	5500	2450	6161	6546	1789	1404	3/6	1750	2050	1900	2100
	XCP25N600	6000	2650	6661	7046	1989	1604	3/6	1550	1850	1800	1950
	XCP25N650	6500	2850	7161	7546	2189	1804	3/6	/	/	1550	1800

With sideshifter minus 150kg, with integrated sideshifter minus 100kg.

3.0t Mast Specification

Type	Model	Max. fork height	Overall height			Free lift height		Tilt range	Capacity			
			Lowered	Extended		Without backrest	With backrest		Load Capacity at 500mm			
				Without backrest	With backrest				Single Tire		Double tire	
									3.0t	3.0t		kg
Wide view Duplex mast	XCP30M270	2700	1857	3386	3842	145	145	6/12	3000	3000		
	XCP30M300	3000	2007	3686	4142	145	145	6/12	3000	3000		
	XCP30M330	3300	2157	3986	4442	145	145	6/12	3000	3000		
	XCP30M350	3500	2257	4186	4642	145	145	6/12	3000	3000		
	XCP30M370	3700	2407	4386	4842	145	145	6/12	3000	3000		
	XCP30M400	4000	2607	4686	5142	145	145	6/12	3000	3000		
	XCP30M450	4500	2857	5186	5642	145	145	6/6	3000	3000		
	XCP30M500	5000	3107	5686	6142	145	145	6/6	2850	2900		
Free duplex wide-view mast	XCP30U270	2700	1907	3440	3842	1152	765	6/12	3000	3000		
	XCP30U300	3000	2057	3740	4142	1302	915	6/12	3000	3000		
	XCP30U330	3300	2207	4040	4442	1452	1065	6/12	3000	3000		
	XCP30U350	3500	2307	4240	4642	1552	1165	6/12	3000	3000		
	XCP30U370	3700	2407	4440	4842	1652	1265	6/12	3000	3000		
	XCP30U400	4000	2607	4740	5142	1852	1465	6/12	3000	3000		
Free triplex wide-view mast	XCP30N400	4000	2007	4730	5142	1277	865	6/6	3000	3000		
	XCP30N430	4300	2107	5030	5442	1377	965	6/6	3000	3000		
	XCP30N450	4500	2157	5230	5642	1427	1015	6/6	3000	3000		
	XCP30N470	4700	2257	5430	5842	1527	1115	6/6	2900	2950		
	XCP30N480	4800	2307	5530	5942	1577	1165	6/6	2900	2950		
	XCP30N500	5000	2407	5730	6142	1677	1265	6/6	2850	2900		
	XCP30N550	5500	2607	6230	6642	1877	1465	3/6	2670	2750		
	XCP30N600	6000	2857	6730	7142	2127	1715	3/6	2350	2500		
	XCP30N650	6500	3057	7230	7642	2327	1915	3/6	/	2200		

With sideshifter minus 200kg, with integrated sideshifter minus 100kg.

3.5-3.8t Mast Specification

Type	Model	Max. fork height	Overall height			Free lift height		Tilt range	Capacity			
			Lowered	Extended		Without backrest	With backrest		Load Capacity at 500mm			
				Without backrest	With backrest				Single Tire		Double tire	
									3.5t	3.8t	3.5t	3.8t
Wide view Duplex mast	XCP35M270	2700	2007	3486	3842	150	150	6/12	3500	3800	3500	3800
	XCP35M300	3000	2157	3786	4142	150	150	6/12	3500	3800	3500	3800
	XCP35M330	3300	2307	4086	4442	150	150	6/12	3500	3800	3500	3800
	XCP35M350	3500	2407	4286	4642	150	150	6/12	3500	3800	3500	3800
	XCP35M370	3700	2507	4486	4842	150	150	6/12	3500	3800	3500	3800
	XCP35M400	4000	2757	4786	5142	150	150	6/12	3500	3800	3500	3800
	XCP35M450	4500	3007	5286	5642	150	150	6/6	3300	3600	3400	3700
	XCP35M500	5000	3257	5786	6142	150	150	6/6	3100	3400	2900	3500
	XCP35U270	2700	2007	3530	3842	1177	865	6/12	3500	3800	3500	3800
Free duplex wide-view mast	XCP35U300	3000	2157	3830	4142	1327	1015	6/12	3500	3800	3500	3800
	XCP35U330	3300	2307	4130	4442	1477	1165	6/12	3500	3800	3500	3800
	XCP35U350	3500	2407	4330	4642	1577	1265	6/12	3500	3800	3500	3800
	XCP35U370	3700	2507	4530	4842	1677	1365	6/12	3500	3800	3500	3800
	XCP35U400	4000	2707	4830	5142	1877	1565	6/12	3500	3800	3500	3800
	XCP35N400	4000	2107	4830	5142	1277	965	6/6	3500	3700	3500	3800
Free triplex wide-view mast	XCP35N430	4300	2207	5130	5442	1377	1065	6/6	340			

Technical data(with high vision)

Distinguishing mark	HANGCHA GROUP CO.,LTD.						
	1.1	Manufacturer		CPD20-XCY2-SIGW	CPD25-XCY2-SIGW	CPD30-XCY2-SIGW	CPD35-XCY2-SIGW
1.2	Manufacturer's type designation		CPD20-XCY2-SIGW	CPD25-XCY2-SIGW	CPD30-XCY2-SIGW	CPD35-XCY2-SIGW	CPD35-XCY2-SIGW
1.3	Drive: electric (battery or mains), diesel, petrol, fuel gas		Electric	Electric	Electric	Electric	Electric
1.4	Operator type: hand, pedestrian, standing, seated, order-picker		Seated	Seated	Seated	Seated	Seated
1.5	Rated capacity /rated load	Q (kg)	2000	2500	3000	3500	3500
1.6	Load centre distance	c (mm)	500	500	500	500	500
1.8	Load distance, centre of drive axle to fork	x (mm)	431	431	463	478	478
1.9	Wheelbase	y (mm)	1520	1520	1650	1650	1650
2.1	Service Weight	kg	3580	3920	4620	5100	5100
2.2	Axle loading, laden front/rear	kg	4900/680	5690/730	6660/923	7575/950	7575/950
2.3	Axle loading, unladen front/rear	kg	1660/1920	1635/2285	1914/2670	2010/3020	2010/3020
3.1	Tyres: solid rubber, superelastic, pneumatic, polyurethane		pneumatic	pneumatic	pneumatic	solid rubber	solid rubber
3.2	Tyre size, front		23-9-10-18PR	23-9-10-18PR	23-10-12-18PR	23-10-12	23-10-12
3.3	Tyre size, rear		18.7-8-14PR	18.7-8-14PR	18.7-8-16PR	200/50	200/50
3.5	Wheels, number front / rear (x = driven wheels)		2x/2	2x/2	2x/2	2x/2	2x/2
3.6	Tread, front	b10 (mm)	1046	1046	1044	1044	1044
3.7	Tread, rear	b11 (mm)	960	960	960	950	950
4.1	Tilt of mast/fork carriage forward/backward	$\alpha/\beta(^{\circ})$	6/12	6/12	6/12	6/12	6/12
4.2	Height, mast lowered	h1 (mm)	2000	2000	2007	2157	2157
4.3	Free lift	h2 (mm)	140	140	145	150	150
4.4	Lift	h3 (mm)	3000	3000	3000	3000	3000
4.5	Height, mast extended	h4 (mm)	4046	4046	4142	4142	4142
4.7	Height of overhead guard	h6 (mm)	2550	2550	2550	2550	2550
4.8	Seat height/stand height	h7 (mm)	1555	1555	1605	1605	1605
4.12	Coupling height	h10 (mm)	400	400	390	390	390
4.19	Overall length	l1 (mm)	3376	3376	3553	3568	3568
4.20	Length to face of forks	l2 (mm)	2306	2306	2483	2498	2498
4.21	Overall width	b1 (mm)	1271	1271	1298	1298	1298
4.22	Fork dimensions	s/e/l(mm)	40/122/1070	40/122/1070	45/122/1070	50/122/1070	50/122/1070
4.23	Fork carriage DIN 15 173 --- ISO 2328, class/type A,B		ISO2328 2A	ISO2328 2A	ISO2328 3A	ISO2328 3A	ISO2328 3A
4.24	Fork-carriage width	b3 (mm)	1038	1038	1038	1100	1100
4.25	Distance between fork-arms	b5 (mm)	776	776	838	838	838
4.31	Ground clearance, laden, below mast	m1 (mm)	120	120	127	127	127
4.32	Ground clearance, centre of wheelbase	m2 (mm)	125	125	125	125	125
4.34.1	Aisle width for pallets 1000 x 1200 crossways	Ast (mm)	3786	3786	3848	3863	3863
4.34.2	Aisle width for pallets 800 x 1200 lengthways	Ast (mm)	3914	3914	4048	4063	4063
4.35	Turning radius	Wa (mm)	2035	2035	2185	2185	2185
5.1	Travel speed, laden/unladen	km/h	16/17	16/17	16/17	16/17	16/17
5.2	Lift speed, laden/unladen	m/s	0.35/0.46	0.35/0.46	0.35/0.46	0.35/0.46	0.35/0.46
5.3	Lowering speed, laden/unladen	m/s	0.51/0.54	0.51/0.54	0.50/0.53	0.50/0.53	0.50/0.53
5.6	Max. Drawbar pull, laden/unladen	N	12000/11000	12000/11000	13000/12000	13000/12000	13000/12000
5.8	Max. gradeability, laden/unladen	%	15/25	15/25	15/25	15/25	15/25
5.9	Acceleration time, laden/unladen (0-10m)	s	5.1/5.0	5.1/5.0	5.9/5.4	5.9/5.4	5.9/5.4
5.10	Service brake		HYdraulic	HYdraulic	HYdraulic	HYdraulic	HYdraulic
5.11	Parking brake		Mechanical	Mechanical	Mechanical	Mechanical	Mechanical
6.1	Drive motor rating S2 60 min	KW	17	17	17	17	17
6.2	Lift motor rating at S3 15%	KW	23	23	23	23	23
6.3	Battery acc. to DIN 43531/35/36 A,B,C, no		no	no	no	no	no
6.4	Battery voltage, nominal capacity K5	V / Ah	80/230	80/230	80/304	80/304	80/304
6.5	Battery weight	kg	±180	±180	±220	±220	±220
10.1	Operating pressure for attachments	bar	±160	±160	±160	±160	±160
10.2	Oil volume for attachments	L / min	25	25	25	25	25
10.3	Hydraulic Tank - capacity (drain & refill)	L	31	31	31	31	31
10.7	Sound pressure level at the driver's seat	dB (A)	≤70	≤70	≤70	≤70	≤70

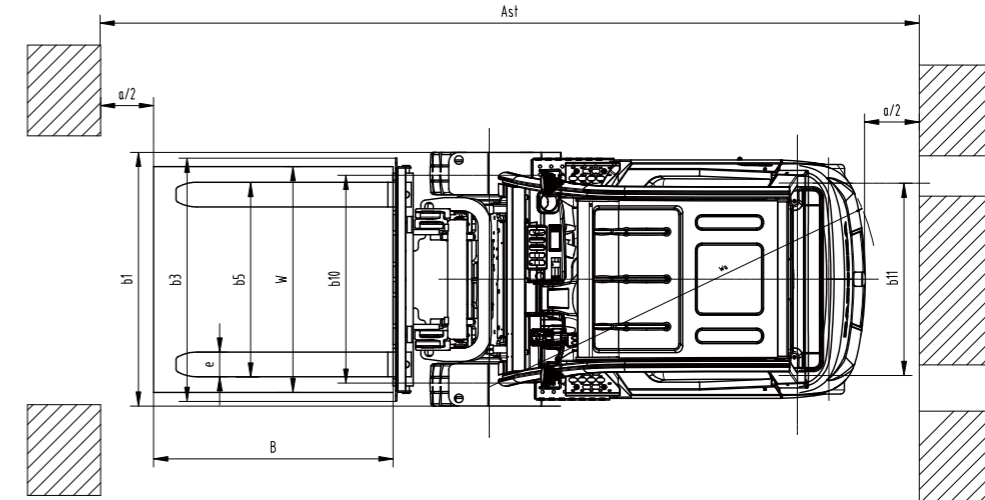
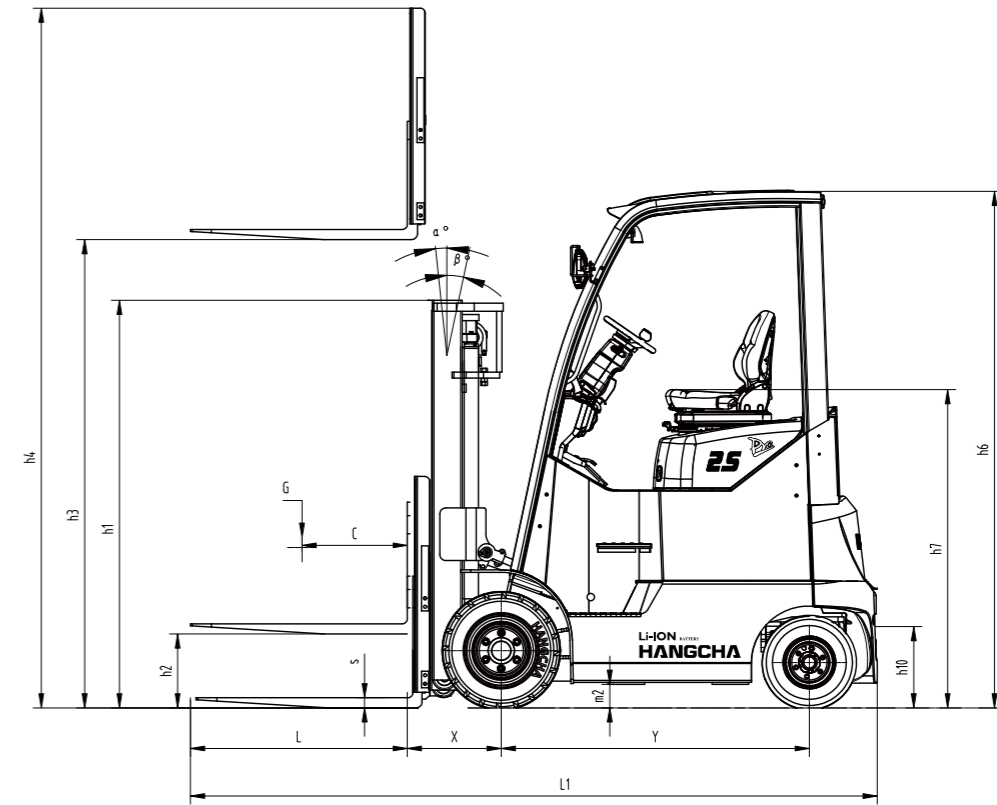

a=200 mm safety clearance
AST=a+Wa+X+B

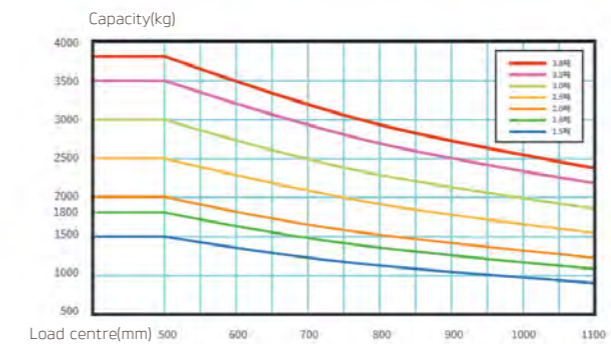

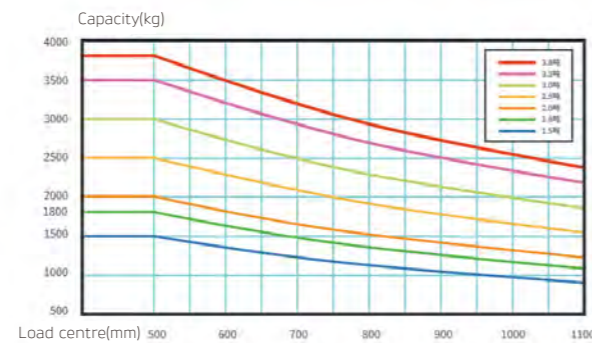
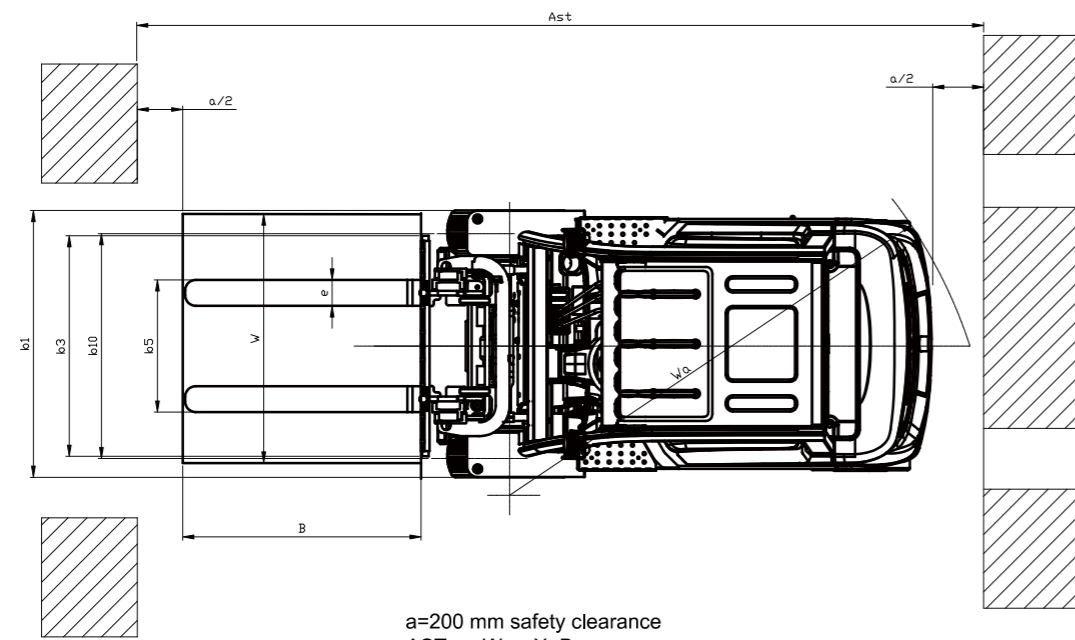
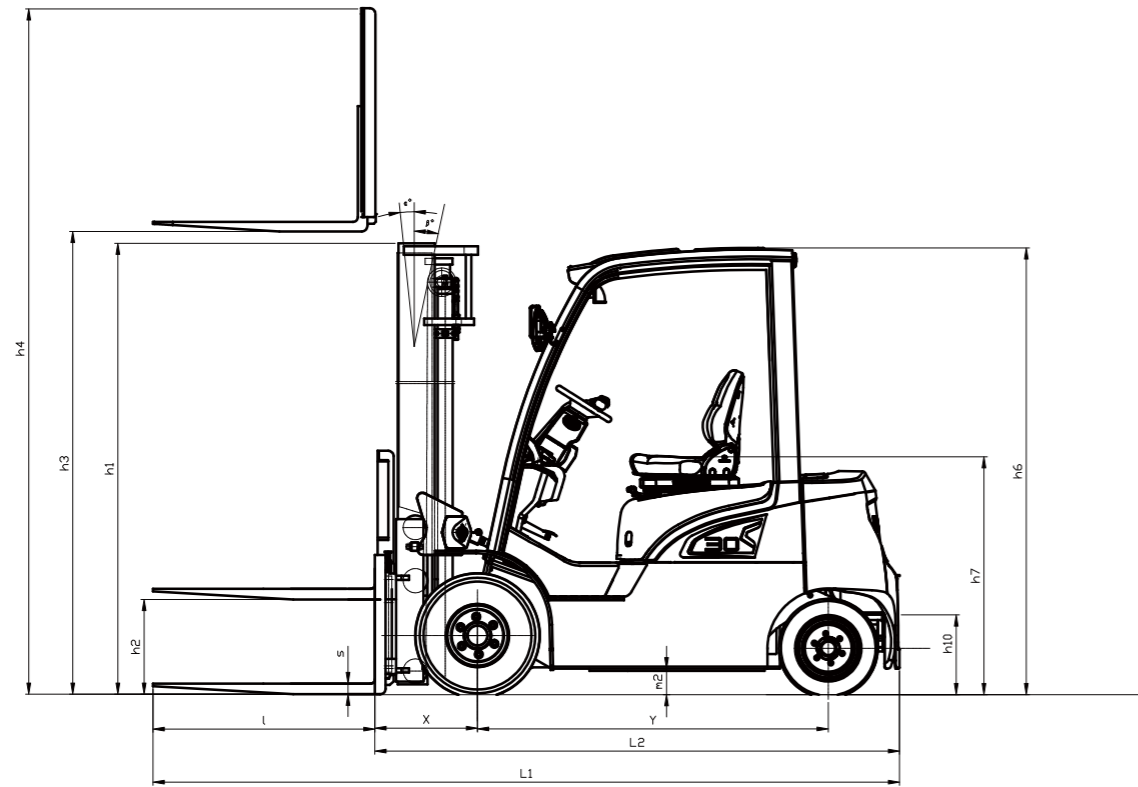

Features

No.	Configuration	Standard	Options
1	Color	Dark green	Other customized color
2	Particular market	/	CE Standard
3	Cold storage environment	/	-30°C
4	Mast	Standard duplex mast	Configuration Table of the Mast
5	Fork and attachment	Standard fork Fork arm carrier Load backrest	Non-standard series fork Various attachments
6	Tires	Pneumatic tire (single)	Pneumatic tire (dual) Solid tire (single) Solid tire (dual)
7	Multiway valve	Double multi-way valve	Triple valve Quadruple valve Quintuple valve
8	Tiller	Lifting and tilting Level	Thumb switch Handle Rocker switch and armrest
9	Battery	Standard lithium battery	Large-capacity lithium battery Quick-change lithium battery
10	Light	LED head lamp Turn signal lamp LED rear combination lamp	Common alarm lamp Acoustic and optical alarm lamp LED rear lamp Blue light Straight projection lamp
11	Horn	Electric horn Reverse buzzer	Right rear armrest with horn button
12	Smart module	/	FIMS(Fleet intelligent management system)
13	Safety configuration	Emergency power-off switch Fuse box Soft landing	Reversing radar DPS system Fire extinguisher Ascending buffering
14	Parking brake	Mechanical handbrake	EPB(Electric Parking Brake)
15	Driving brake	Hydraulic assisted braking	/
16	Instrument rack space	Smart color-screen instrument (speed mode selection) Combination switch	Cigarette lighter USB port Electronic code lock (start by swiping a card)
17	Driving space	Standard overhead guard Central rear view mirror PVC ceiling	Front windshield Cab Electric fan Left and right rear view mirrors
18	Seat	Standard seat	Fully-suspended seat Semi-suspended seat
19	Other standard configuration	Oil pump reducer Silent gear pump DC-DC converter Pedal pad Traction pin Integral stamped side panel and hood	/